

Electric Curtain Track System Silent Gliss® 5300



Electric Curtain Track System Silent Gliss® 5300

5301

1:2

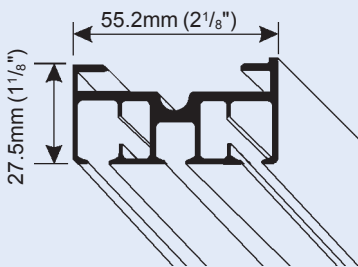

Product Information

- #5300 is a medium to heavy duty motorized drapery track system
- Unique "cylinder-chain" drive belt minimizes friction and guarantees smooth, reliable operation
- Multi-channel profile permits unlimited overlap
- Electronic motor with built-in low voltage switching capabilities and thermal overload protection
- Built in low voltage interface allows direct access to all automated control systems
- Optional Infrared Remote Control, Timer, Sun Sensor by simple plug-in module (see section Controls and Electrical Data)
- System limits may be set from either switch locations or remote transmitter and are protected during power failure
- System can be curved or bent on both inside and outside radii
- Accommodates Pinch Pleat, S-fold or Z-fold drapery headings (see section "appendix" for additional S/Z-fold information)
- Motor concealed behind drapery when mounted below the track
- Motor can be mounted above or below the track
- Single, multiple or asymmetrical stacking
- Optional crank for manual over ride during power failure
- Operation from multiple individual switches and/or a master switch is possible without any additional control devices
- Particularly suitable for offices, hotels, institutions, theaters, stages and auditoriums
- 5 Year Limited Warranty



Can be bent
Min. radius R
5301 = 500mm (20")

System Configurations and Maximum Drapery Weights

	5m (17')	10m (32')	15m (50')	20m (64')	25m (82')
	70kg (154lb)	65kg (143lb)	60kg (132lb)	55kg (121lb)	50kg (110lb)
	75kg (165lb)	65kg (143lb)	60kg (132lb)	55kg (121lb)	50kg (110lb)
	60kg (132lb)	55kg (121lb)	50kg (110lb)	45kg (99lb)	40kg (88lb)
	60kg (132lb)	55kg (121lb)	50kg (110lb)	45kg (99lb)	40kg (88lb)
	55kg (121lb)	50kg (110lb)	45kg (99lb)	40kg (88lb)	35kg (77lb)
	55kg (121lb)	50kg (110lb)	45kg (99lb)	40kg (88lb)	35kg (77lb)
	29kg (63lb)	25kg (55lb)	22kg (48lb)	18kg (39lb)	16kg (35lb)
	29kg (63lb)	25kg (55lb)	22kg (48lb)	18kg (39lb)	16kg (35lb)
	23kg (50lb)	20kg (44lb)	*Note: Consult Silent Gliss for larger curved sizes.		
	23kg (50lb)	20kg (44lb)			

For applications where drapery weight exceeds 800 grm (1.8 lbs) per roller, use heavy duty roller #5201.

Formula to arrive at drapery weight: $A \times B \times C \times D = \text{lbs.}$ ** To arrive from ft.² to yd.²
9** x 16*** ***Convert oz. into lbs.

Example
 Rail Length (A): 30 ft. (straight) 30 x 12 x 2* x 15 = 75 lbs.
 Drapery Height (B): 12 ft. 9** x 16***
 Drapery Fullness (C): 2 = 100% (double) fullness or
 2.2 = 120% fullness, etc.
 Drapery Weight (D): 15 oz./y²

Conclusion:
5300 system can be used.

Electric Curtain Track System Silent Gliss® 5300

Installation

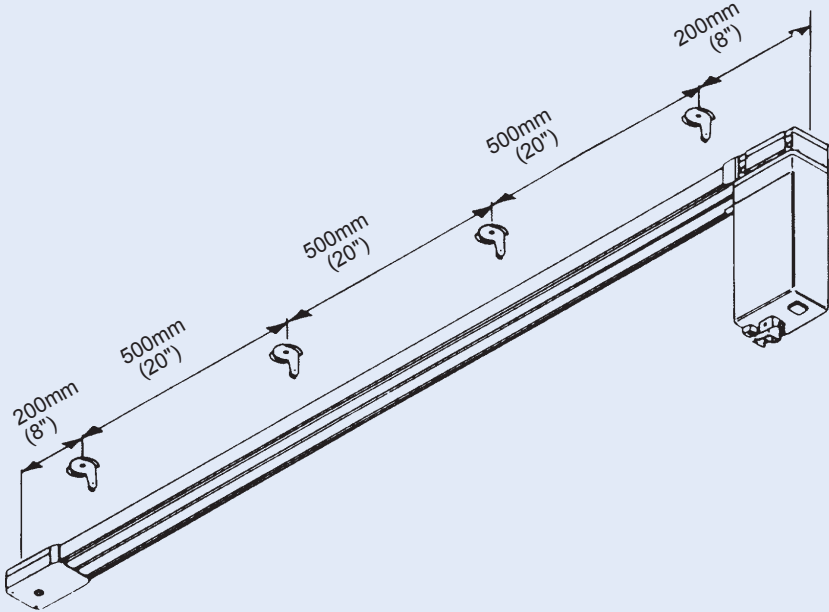

Ceiling Mount

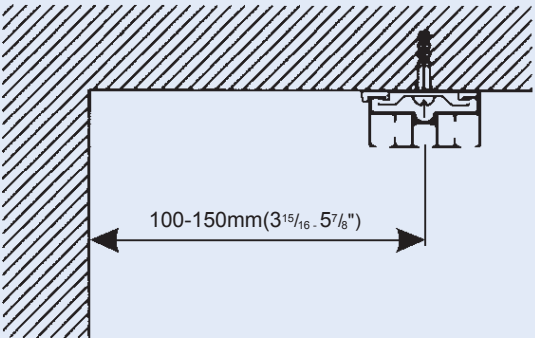

Clamp #5320 spaced approximately 50cm (20") o.c.

Wall Mount

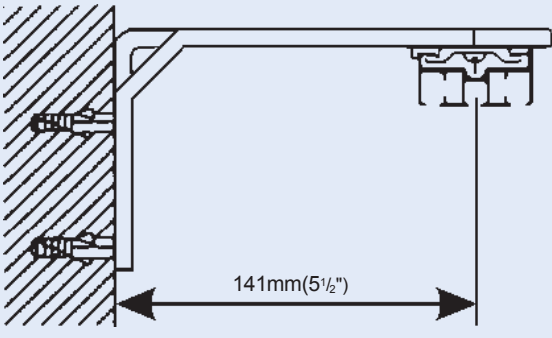

Bracket #3239 spaced approximately 50cm (20") o.c.

Motor recessed with profile mounted to ceiling

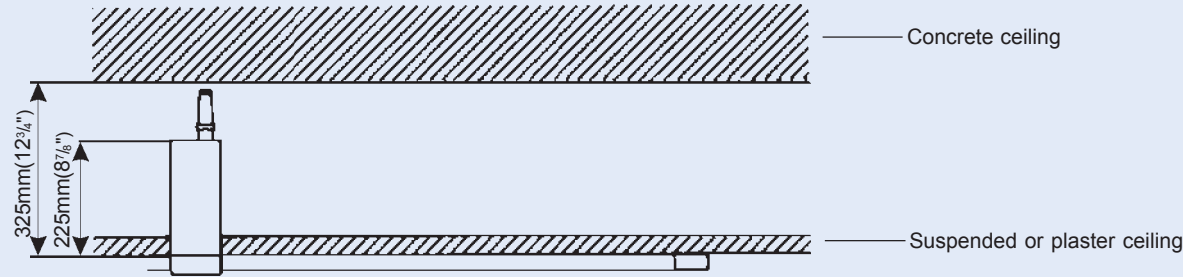

© Copyright by Silent Gliss 2004

Electric Curtain Track System Silent Gliss® 5300

Electrical Information

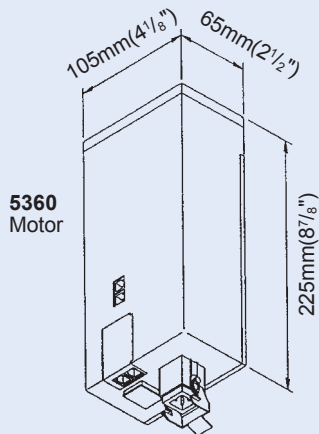

5360
Motor



5685
Plug

Motor data
Interference-free electronic motor
Thermal Overload Protection
Speed: 30cm/sec (12"/sec)
110V/60Hz/150W/1.0Amp

(Export Version)
230V/60Hz/150w/1.0Amp

Operating Methods

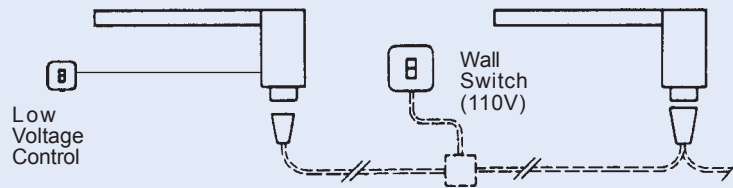

Low
Voltage
Control

Wall
Switch
(110V)

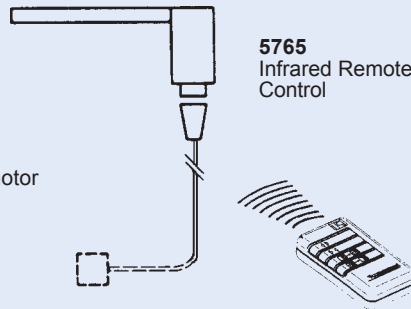

5765
Infrared Remote
Control

For additional
information on
controls and
electrical wiring
refer to section
"Controls and
Electrical Data".

Standard Components



5320
Clamp



6098
Roller Glider
with eyelet



6086
Spring Stop

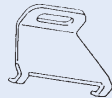

5318
Motor
Bracket

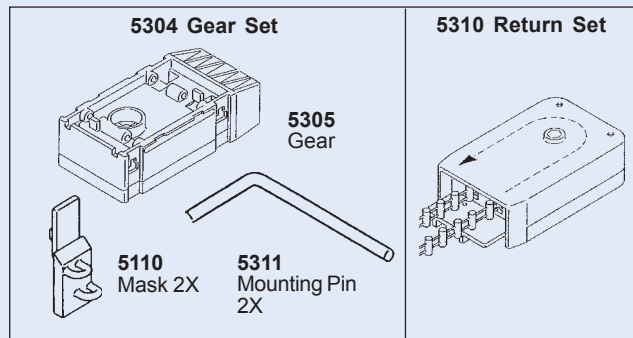

5304 Gear Set

5310 Return Set

5305
Gear



5110
Mask 2X

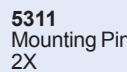

5311
Mounting Pin
2X

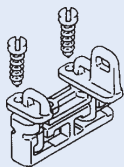

5321
Pilot

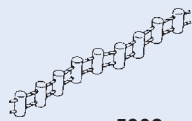

5302
Drive Chain



5312
Return Mask

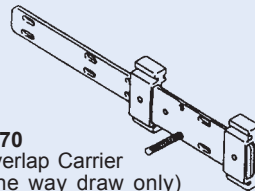

5670
Overlap Carrier
(one way draw only)

Optional Components

S-fold/Z-fold
components
refer to
section
"appendix"



5201
Roller



6094
Roller
with Hook

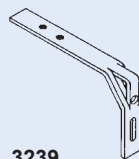

3239
Wall Bracket

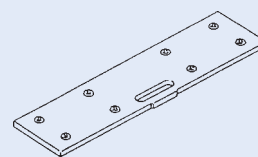

5319
Connecting Bridge