

Electrically Operated Curtain Track System Silent Gliss® 5800

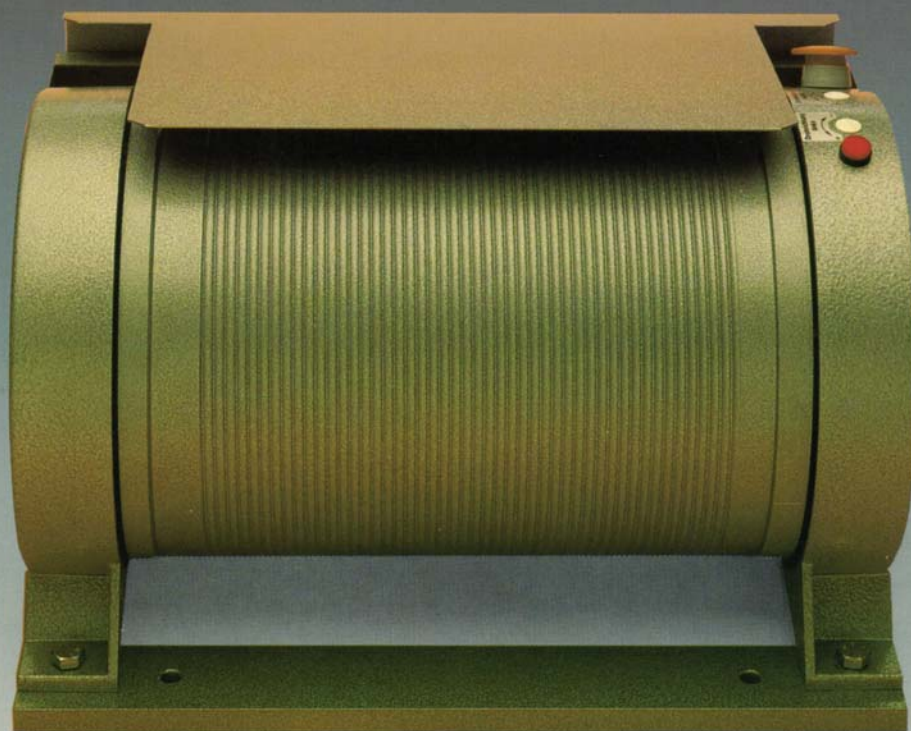

© Copyright by Silent Gliss 2004

Electrically Operated Curtain Track System Silent Gliss® 5800

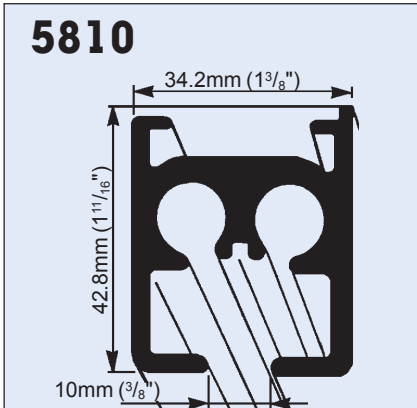

Product Information

- For very heavy installations
- Exceptionally neat profile for size of system, especially compared with traditional stage tracks
- Extremely wide choice of stacking and bending options including multiple stacking
- Profiles can be mounted in parallel for increased overlap
- Crank override in case of power failure and emergency stop button
- Floor or wall mounting of motor
- Non-stretch steel core rope in internal channels
- Automatic limit switches and built-in thermal overload
- Motor speed 20cm per second
- Can be used with remote control
- Systems may be up to 60m long and curtains 280kg in weight
- 5 Year Limited Warranty

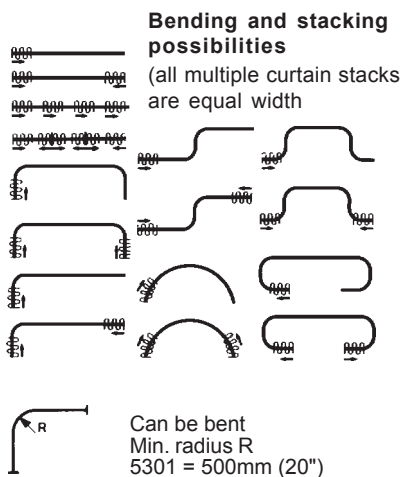

Installation

Ceiling Mount only with 6209 clamps

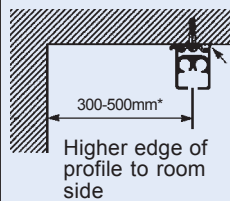

6209 Clamp

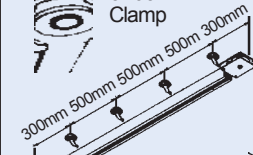

Optional floor or standard wall fixing for motor

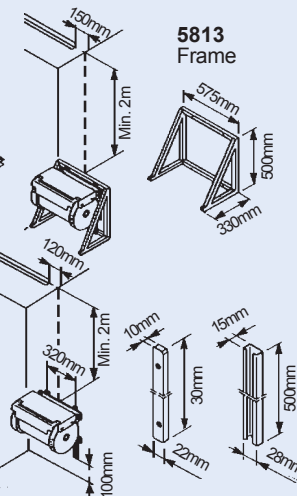
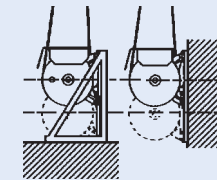

Operating Methods

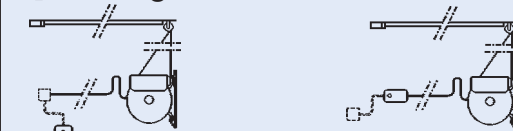

Fixed switch or remote control

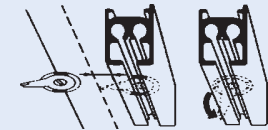

(Timber soffit at least 4cm thick over complete length of track is recommended.) This motor is enormously strong and both mounting points and ceiling must be solid.

Two profiles in parallel

Where 2 profiles are mounted in parallel (for better overlapping), a minimum distance of 76mm must be observed between centre parts of return pulleys but this may be more depending on room needed for curtain heading.

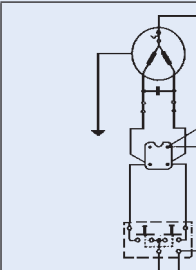
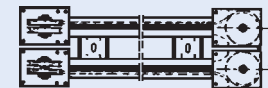

Motor Data

Interference-free asynchronous motor. Not double-insulated - earth required. Motor weight 30.3kg.

UK & export versions available

220v / 50Hz / 500 Watt / 2.2 amps
240v / 50Hz / 500 Watt / 2 amps
110v / 60Hz / 500 Watt / 5 amps

Standard Accessories

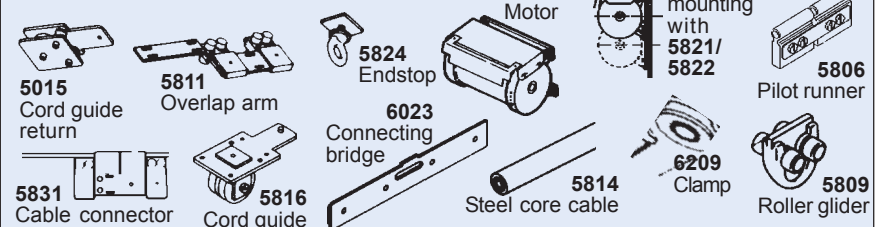

Optional Accessories



5813 Floor mounting frame

Max. Curtain Weights	10m	20m	30m	40m	50m	60m
	260	240	220			
	280	260	240	220	200	180
	200	180	160			
	200	180	170	160	150	140
	140	130	120			
	150	140	130	120	110	100
	70	65	60			
	70	65	60	55	50	45
	60	50	40			
	60	50	40			